

REVISIONS				
ZONE	REV	DESCRIPTION	DATE	APPROVED

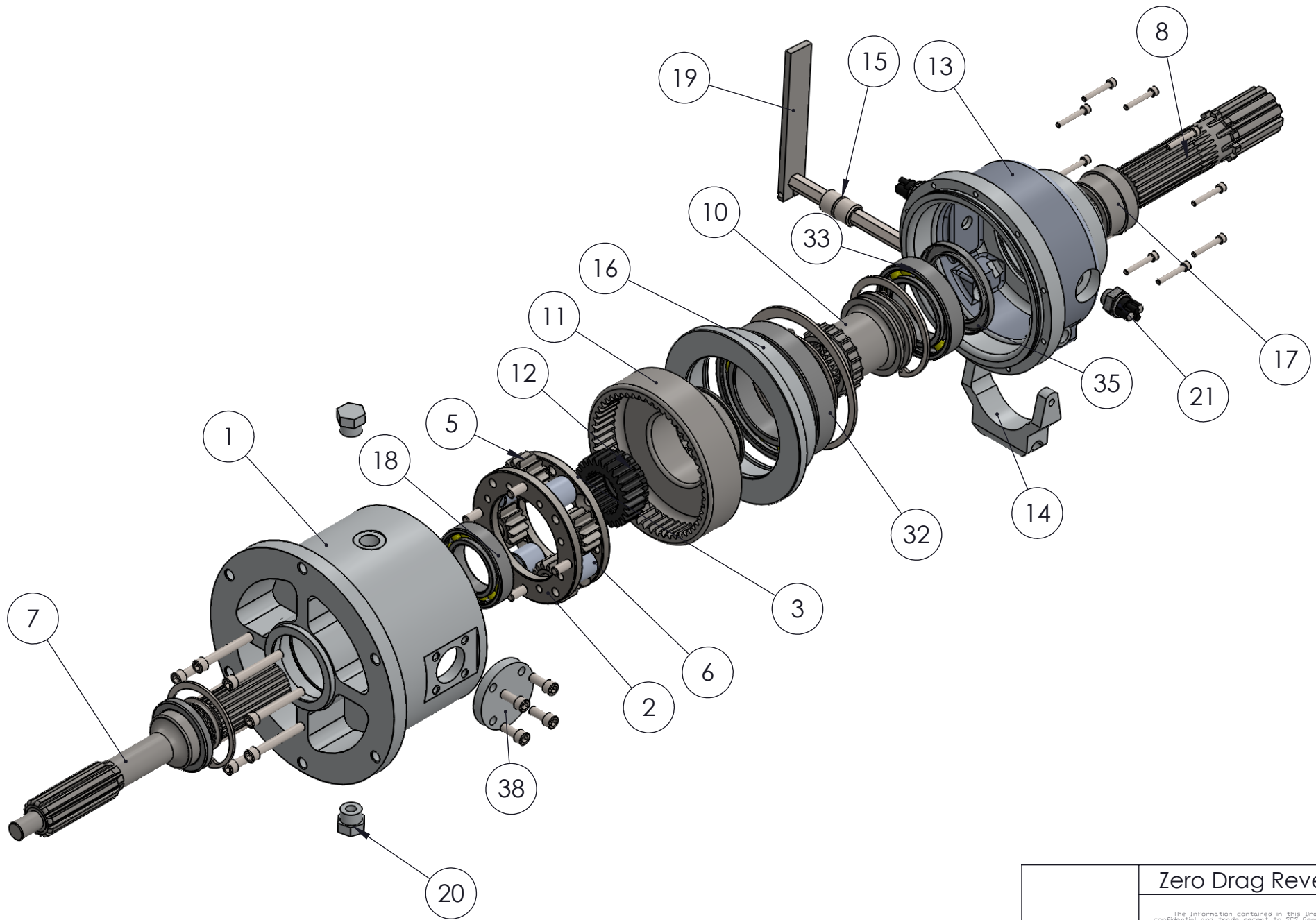

		Zero Drag Reverser		
The information contained in this drawing is confidential and trade secret to SCS Gearbox, and is not to be disclosed without release from the V.P. of Engineering.				
739 West Main St. Bellevue, OH. 44811		SIZE	FORM NO.	DWG NO.
SCALE				SHEET

REVISIONS				
ZONE	REV	DESCRIPTION	DATE	APPROVED

ITEM NO.	PART NUMBER	QTY.
1	Zero drag housing	1
2	Zero drag Planetary Bottom Plate	1
3	10 Series Planetary Bottom Plate	1
4	10 Series Planetary Pin	4
5	10 Series Planetary Gear	4
6	10 Series Planetary Stand	4
7	Zero drag input shaft	1
8	Zero drag output shaft	1
9	Zero drag Split Bushing	1
10	Zero drag shift collar	1
11	Zero drag ring gear	1
12	Zero drag sun gear	1
13	10 Series Case	1
14	10 Series Shift Fork	1
15	10 Series Hex Shaft	1
16	10 Series Bearing Support	1
17	Zero drag output shaft sleeve	1
18	6009-C3	1
19	Shift Lever	1
20	Drain Plug	2
21	Allison Transmission Sensor	2
22	10-24x1.25 Cap Screw	10
23	5/16-24x2.25 Cap Screw	8
24	5/16-18x1 Cap Screw	4
25	B27.1 - NA2-300	1
26	B27.1 - NA2-500	1
27	B27.1 - NA2-350	1
28	B27.1 - NA1-212	1
29	B27.1 - NA1-315	1
30	B27.1 - NA1-175	1
31	B27.1 - NA1-50	1
32	Lee Spring 1.125	2
33	0.187 Ball	2
34	6016-C3	1
35	6011-C3	1
36	CR_19777	1
37	CR_23447	1
38	1.0in Shift Fork Pin	2
39	Koyo B-108	1
40	10 Series brake cap	1
41	5/16-18 x 0.75 Cap Screw	4

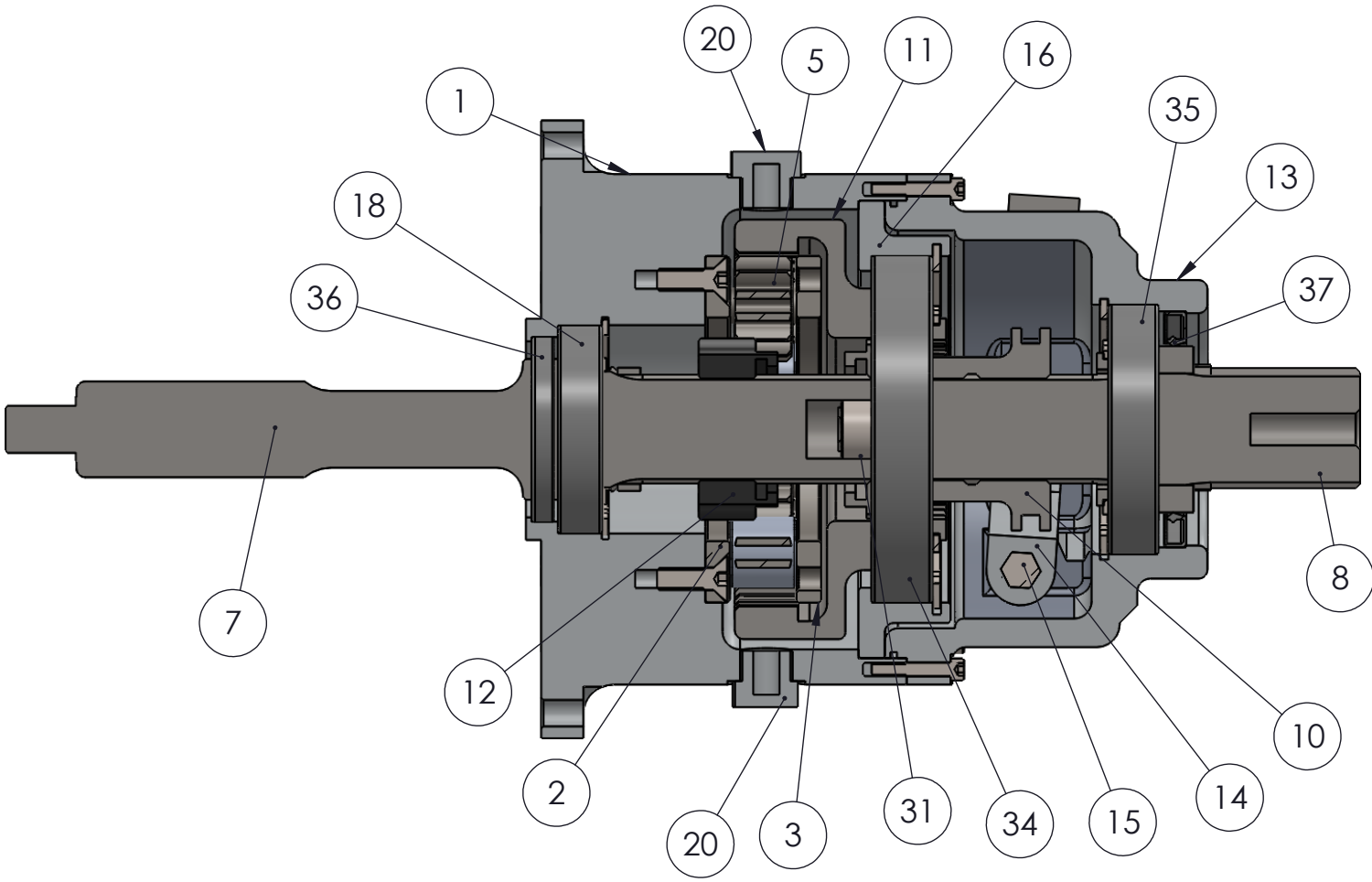

SECTION A-A
SCALE 1 : 2.5

Zero Drag Reverser

The Information contained in this Drawing is confidential and trade secret to SCS Gearbox, and is not to be disclosed without release from the V.P. of Engineering.

739 West Main St. Bellevue, OH. 44811		SIZE	FORM NO.	DWG NO.	REV
SCALE					SHEET