

$\varnothing .390 [9.906]$ Thru
 $\varnothing 0.625 [15.875] \nabla 0.900 [22.86]$
 Counterbore so bolts clear gear

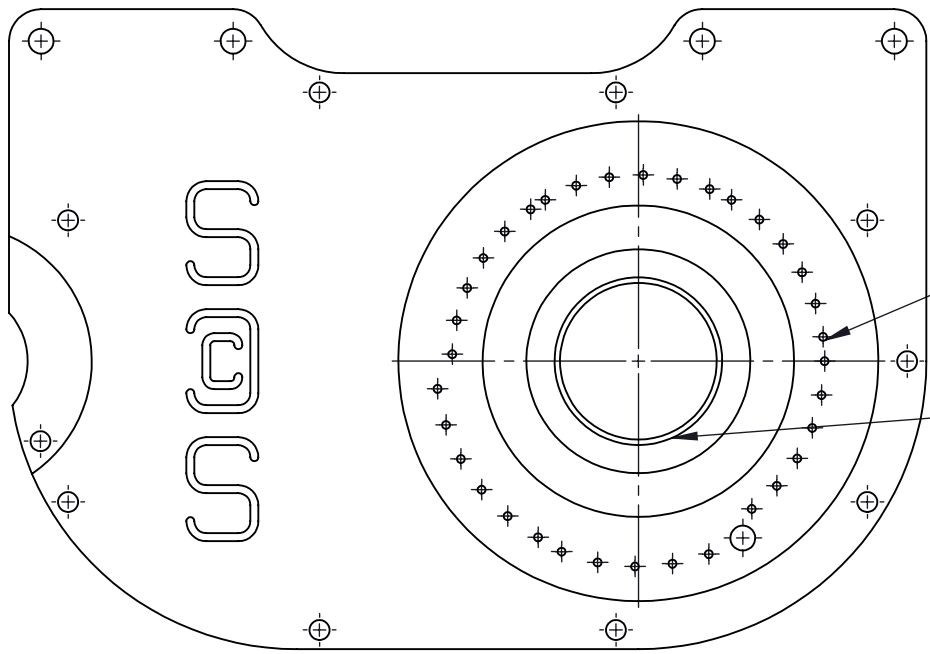

Use Centerdrill marks to drill holes at desired position

Install SKF 17448 seal before final assembly

Tolerances

X.XX ± .015
X.XXX ± .005
X.XXXX ± .0005

739 West Main St.
 Bellevue, OH. 44811

Turbo 400 Straight Thru Drill Instructions

The Information contained in this Drawing is confidential and trade secret to SCS Gearbox, and is not to be disclosed without release from the V.P. of Engineering

SIZE	Material:	Heat Treat:	REV
SCALE			SHEET