

3 Speed Transmission

The information contained in this drawing is confidential and trade secret to SCS Gearbox, and is not to be disclosed without release from the V.P. of Engineering.

739 West Main St. Bellevue, OH. 44811	SIZE	FORM NO.	DWG NO.	REV
SCALE				SHEET

ITEM NO.	PART NUMBER	Default/QTY.
1	3 speed back case	1
2	3 speed case	1
3	3 Speed Output shaft	1
4	3 Speed Input shaft	1
5	3 Speed counter shaft	2
6	3 Speed Shift Collar	2
7	3 speed brass insert	2
8	3 Speed Rev Gear	1
9	3 Speed Rev Idler Post	1
10	3 Speed Shift Block	1
11	3 Speed Shift Handle	1
12	3 Speed Shifter Block 2	2
13	3 Speed Shifter Cover Plate	1
14	3 Speed Shifter Rod	2
15	32 Tooth Gear 1.000 3 Speed	1
16	33 Tooth 1.065 3 speed	1
17	3 Speed Shift Yoke 1	2
18	3 Speed CS Rev Idler Gear	1
19	3 Speed CS Rev Gear	1
20	brass spacer	1
21	3 Speed Bearing Block	1
22	32 Tooth Gear 1.000	2
23	Shift Pin	1
24	Spring Plunger	2
25	CR_23447	1
26	21267	1
27	31 tooth 1.065	3
28	33 Tooth 1.065	1
29	31 tooth 1.065 3 speed	1
30	3 speed spacer 3	3
31	Koyo B-2020	1
32	209 C3 Ball	4
33	6011-C3	3
34	6009-C3	1
35	5205_A	1
36	BDI .75x .125 O-Ring	4
37	3 speed spacer	2
38	3 speed spacer 4	1
39	B27.1 - NA1-175	3
40	B27.1 - NA1-100	1
41	B27.1 - NA1-206	7
42	B27.1 - NA1-75	4
43	B27.1 - NA1-212	1
44	B27.1 - NA2-206	1
45	B27.1 - NA2-300	1
46	B27.1 - NA2-347	2
47	Preferred Narrow FW 0.375	9
48	Preferred Narrow FW 0.3125	4
49	HBOLT 0.3750-16x5.75x1-N	8
50	SHSSCREW 0.375x0.75-N	1
51	HX-SHCS 0.25-28x1.5x1-N	12
52	HX-SHCS 0.3125-18x1.375x1.375-N	10
53	HJNUT 0.5000-13-D-N	2
54	SSFLATSKT 0.5-13x0.375-HX-N	4
55	Allison Transmission Sensor	2

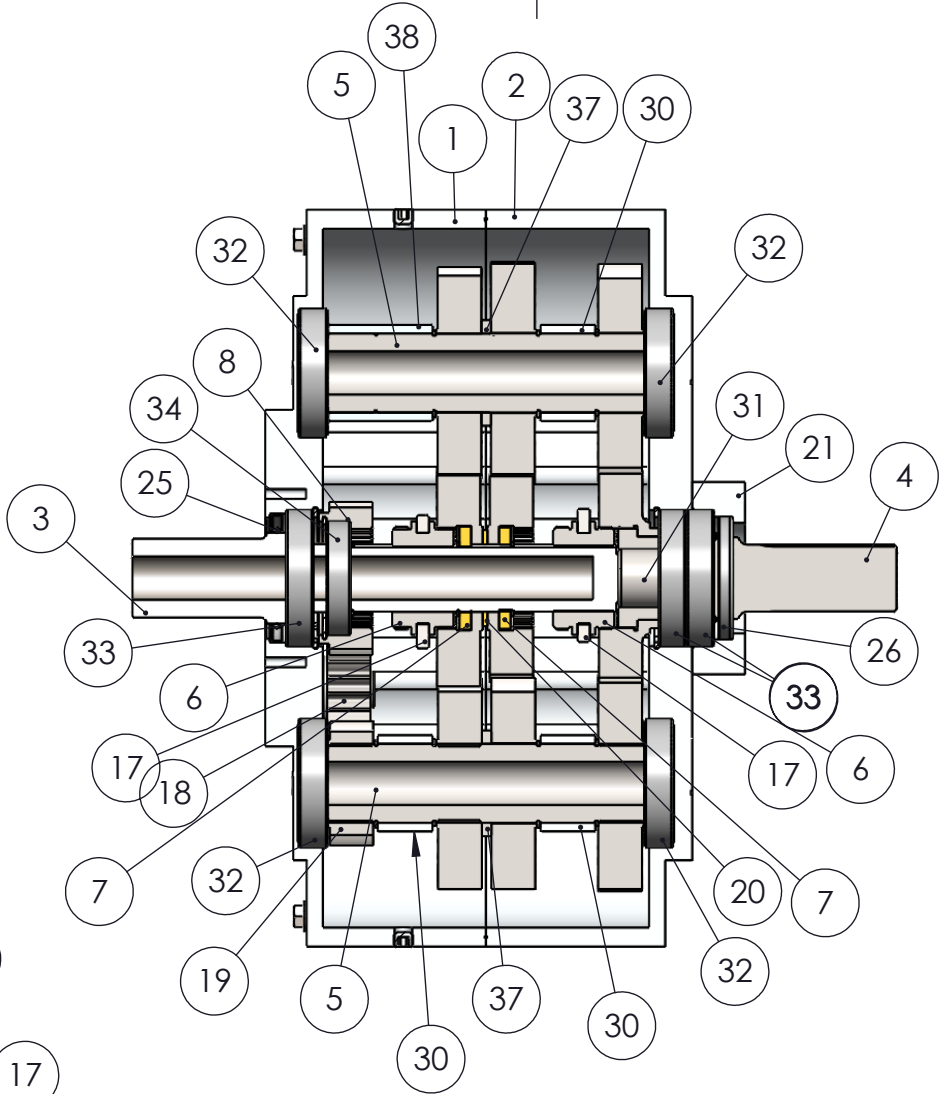
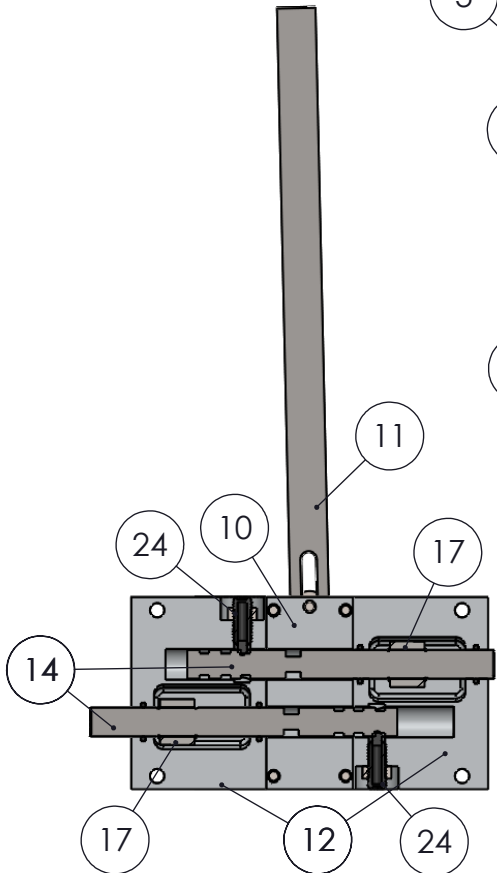

3 Speed Transmission

The information contained in this drawing is confidential and trade secret to SCS Gearbox, and is not to be disclosed without release from the V.P. of Engineering.

REVISIONS				
ZONE	REV	DESCRIPTION	DATE	APPROVED

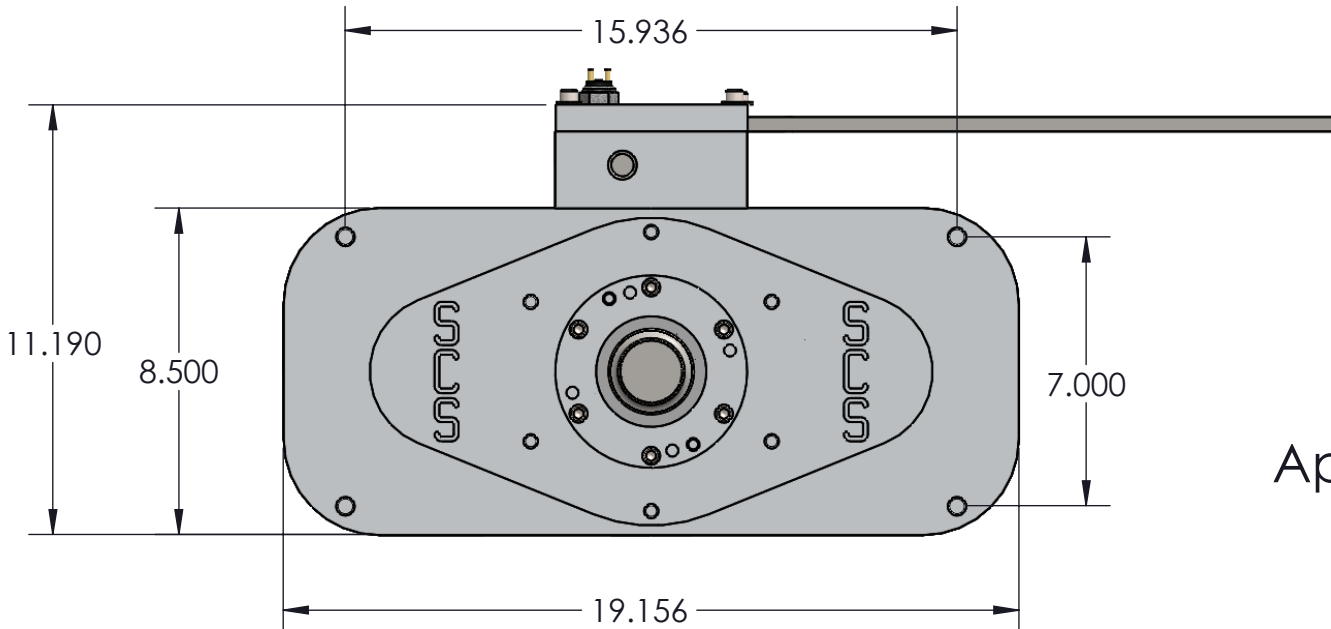
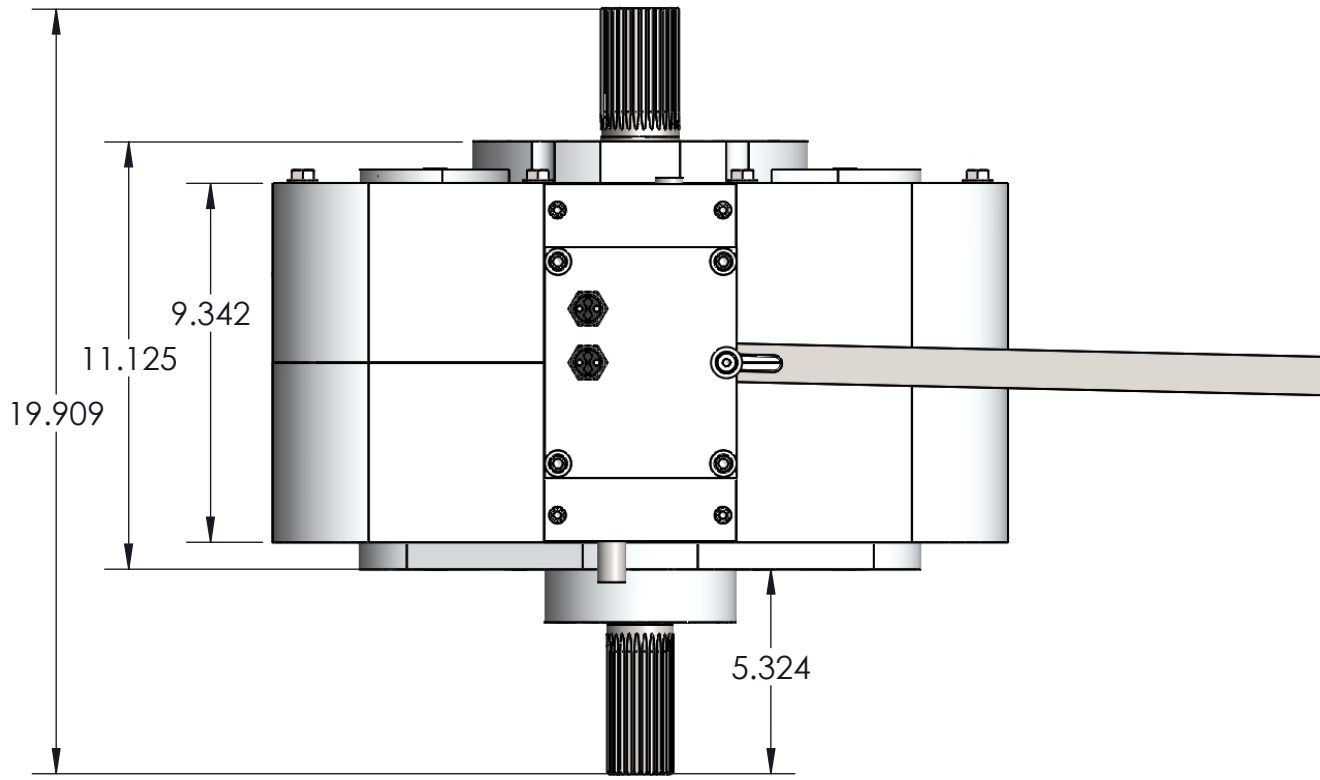

Approx. Weight: 155 lbs



3 Speed Transmission

The information contained in this drawing is confidential and trade secret to SCS Gearbox, and is not to be disclosed without release from the V.P. of Engineering.

739 West Main St. Bellevue, OH. 44811	SIZE	FORM NO.	DWG NO.	REV
SCALE	SHEET			